



STANDARD ELECTRON BEAM EVAPORATORS EBV



EBV 200-100-SR, electron beam evaporator with 100 cm³ hearth, manual linear shutter, refill unit & Si shielding parts

Standard Electron Beam Evaporators EBV are single-pocket UHV evaporation sources recommended for use in any application where low vapor pressure materials (refractory metals, semiconductors, oxides, etc.) have to be evaporated at high rates with high purity over a longer period without evaporant depletion. Consequently, hearth capacities of 40 cm³ and 100 cm³, respectively, ensure a long system uptime.

Only UHV-grade materials are used as construction materials without exception, obtaining a design that is bakeable up to 250°C. In the hot areas of the emitter only high-purity low vapor pressure materials like Mo, Ta, W or Al₂O₃ are present. The electromagnetic coils are manufactured from Kapton™ (polyimide) isolated wires and nickel-plated magnetic steel, the permanent magnets are of a high temperature rare earth material and the single-hearth crucible as well as the surrounding water cooling bores are directly machined into a high purity OFHC-copper block (Oxygen-Free-High-Conductivity Copper). In addition, the special SiGe version of the EBV features a set of high-purity single-crystalline Si shielding parts. Ion bombardment effects on the filament are eliminated by the electron emitter design with 270° beam deflection. This design also shields the sample from direct sight onto the hot filament further reducing the chance of sample contamination by impurities from the hot emitter area.

EBV evaporators are compatible with any MBE system having at least a DN150CF (O.D. 8") horizontal port. As the EBV evaporators are quite heavy pieces of equipment a mounting-slide that is bolted to the chamber port is available. This slide facilitates handling, mounting and servicing of the EBV.

- UHV compatible, low outgassing
- High flux rates of low vapor pressure materials
- High-purity evaporation
- Hearth volumes 40 cm³ or 100 cm³
- Long filament lifetimes
- Easy maintenance
- Optimized version for SiGe MBE with silicon shielding parts



Single-pocket Cu-hearth, capacity 100 cm³

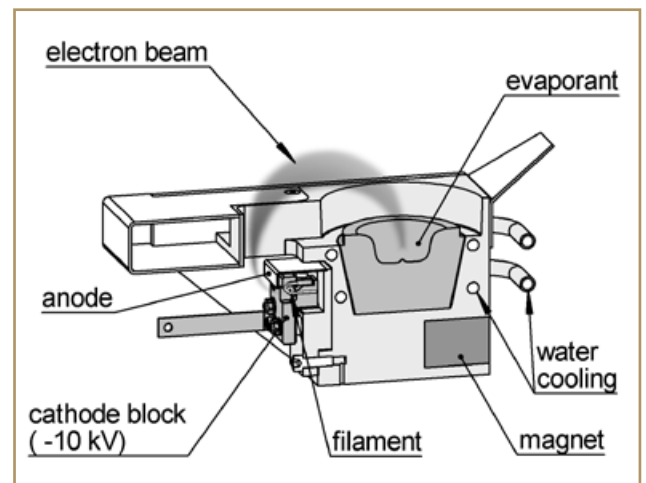

Principle of e-beam evaporator operation with 270° beam deflection

Application

EBV evaporators are designed for high rate evaporation of low-vapour-pressure materials, especially when high purity of the evaporant is desired. They are frequently used for evaporation of refractory metals, e.g. Mo, Nb, Ta, W, Zr, are as well suited for high-rate evaporation of Al, and of course also for semiconductors like Si and Ge.

For application in a SiGe MBE system we provide a specially adapted shielding parts set manufactured from high-purity single-crystalline silicon. These plates and rings cover all parts of the metallic body that are potentially subject to electron or ion bombardment and that face the substrate. We also supply high purity Si and Ge source material in superior quality, machined from wafer-grade single crystals. Whilst the Si charges fit the evaporator hearth closely, the Ge charge is used in combination with a Si crucible liner in order to prevent interaction of the molten Ge with the copper hearth.

For metal deposition the EBV can be used in its standard configuration for all metals that do not melt completely or do not react with the cooled Cu-wall. For some metals, graphite, ceramic or refractory metal crucible liners are used. Ask for the solution for your particular evaporant.

Technical Data

| | |
|--------------------------------|---|
| Mounting Flange | DN150 CF (O.D. 8"), DN200 CF (O.D. 10") or DN250 CF (O.D. 12") |
| Hearth capacities | 40 cm ³ dimensions: Ø51.0mm (15° taper) x 25.5.mm depth 100 cm ³ dimensions: Ø68.0mm (15° taper) x 37.5.mm depth |
| Filament type | short-legged coil of thick W wire, electron emitting filament |
| Bakeout temperature | 250°C (all air side connectors removed) |
| Operating pressure | 1 × 10 ⁻¹¹ mbar 1 × 10 ⁻⁵ mbar |
| Acceleration voltage | 4 - 10 kV |
| Beam power | max. 10 kW (depending on power supply) |
| Filament current | max. 50 A at 10V (AC) |
| Spot size | 5 mm diameter, approx. |
| Primary beam deflection | 270° by permanent magnet system |
| Dynamic beam deflection | coils wound from KAPTON™-isolated wire; deflection frequency: max. 150 Hz; max. x-deflection current: ± 3.0 A; max. y-deflection current: ± 3.0 A |
| Hearth cooling | water flow rate 8 l/min at 4 bar; connectors Swagelok™ Ø8 mm (air side) |
| Options | base flange integrated water cooling roof with custom apertures (K); integrated custom-made source shutter (S) (with optional drive unit LSM 40-100) integrated refill unit ERU 16 (R) |

Schematic drawing of the Standard Electron Beam Evaporator EBV

Drawing shows EBV 250-100-KS with optional integrated source shutter (motor-actuated by LSM 40-100) and water cooling roof

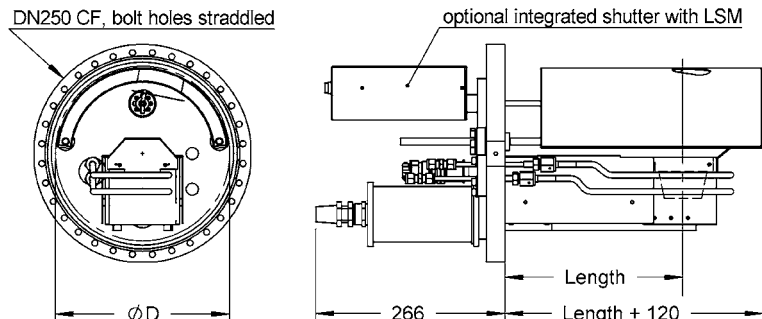

Dr. Eberl MBE-Komponenten GmbH
Gutenbergstrasse 8
71263 Weil der Stadt, Germany
Phone : +49 7033 6937-0
Fax : +49 7033 6937-20



info@mbe-components.com
www.mbe-components.com



Please find your local representative on our website